

# OPERATING GUIDELINES

## DVS-G3® ‘Third Generation’ System

---

### Introduction

Your DVS® system is at the forefront of practical technology, using intelligent software to control airflow, ventilate your home efficiently and maximise the indoor air quality in your home.

On installation of your DVS®, we tailor its settings to the size and layout of your home so that it will operate with optimum efficiency. There are three seasonal settings (‘winter’, ‘summer’ and ‘other’ (used for autumn and spring) called Presets. You will need to activate the change between these presets at the appropriate date (we have not automated this because seasons are different through NZ and from year to year).

Apart from changing seasons, it is possible for you to change some other settings to fine tune your DVS®. We recommend that you do this only after the DVS® has been in operation for a month or so and you have an appreciation of its operation and affect on your home.

These Operating Guidelines explain how you can:

- ü View the current status and settings of your G3® system; and
- ü Change and fine-tune your G3® settings.

We have included information about changing your filter and some frequently asked questions about the G3® in the appendices to this guide. You will find other frequently asked questions about home ventilation in general in our booklet ‘General Guidelines and Principles for All DVS® Systems’.

### Viewing Your Current Status and Settings

To view the status of your DVS® and its current settings go to the LCD touch screen control panel and touch any part of the LCD screen.

This moves you from *Screen-Saver* mode to the *Current Status* screen, which will display the current status of your DVS® as described below.

**NOTE:** Warning or Reminder Screens.

Your LCD screen will alternate between white and black and a warning or reminder will be shown in faint text if:

- ü The power to your DVS® system has been interrupted and the CLOCK needs to be reset (see ‘Resetting or Changing Your Clock’ page 6);
- ü Your air filter is due to be serviced (see ‘Changing Your Filter Service Reminder’ page 6 and Appendix 2); or
- ü It is time to change the pre-set fro the season (see ‘Changing Seasons’ page 5).

In all cases the screen will flash once every 20-30 seconds. Touching the screen once will activate the screen so you can read the message easily.



If a picture of a small child holding a stop sign is showing in the top right hand corner of the screen, this indicates that the CHILD LOCK is on. You will need to deactivate the child lock before you can proceed. To do this follow the steps set out in 'Changing the Child Lock FUNCTION' on page 3.

Please note that in accordance with NZ Standard AS/NZS 60335.1:2002 7.12:

*"This appliance is not intended for use by young children or infirm persons unless they have been adequately supervised by a responsible person to ensure that they can use the appliance safely. Young children should be supervised to ensure that they do not play with the appliance."*

In certain circumstances your screen may be blank and alternating between white and black. Touch the screen and a message will appear about either a power interruption, a reminder to change your seasonal Preset or to remind you to change your filter.

The message for a power interruption will advise you to reset your clock and you will need to do this before you can access the Current Status screen and operate your DVS®. Proceed to reset the clock by following the steps in 'Resetting or Changing your Clock' on page 6.

The Current Status Screen shows icons and other information summarising the current status and main settings of your G3® system, in the **example** shown at right:

- ü Roof-space temperature is 21° Celsius (the reading is shown in the roof-space of the house diagram on the screen);
- ü House temperature is 20° Celsius (the reading is shown in the room space of the house diagram);
- ü The day/time is Thursday 08:43. The day and time showing is the "system" clock time essential for controlling the operation of timers in the system. It is a 24-hour clock.
- ü The Fan symbol at top left showing ON indicates that the fan is operating normally.
  - o If the word BOOST and a time (half-hour, one hour, one and a half hours, or two hours) are showing alongside the fan symbol, this indicates that the fan is operating at maximum speed for the time shown;
  - o If the word TIMER is showing alongside the fan symbol, this indicates that the timer is on and the DVS® will only start working according to the ON and OFF times set.
- ü Preset WINTER is currently the preset selected. The three presets ('WINTER', 'SUMMER' and 'SPR/AUT') will initially have been set by your DVS® installer. They can be altered by using the PRESET function (see 'Changing Seasons' in the next section).
- ü The MENU button is used to access one of the seven operating menus. Pressing it will take you to the MAIN MENU 1 screen, from which by pressing the MORE button you can access MAIN MENU 2 and MAIN MENU 3. The seven operating menus are accessed from the main menu screens.



**Current Status Screen**

## Changing Your G3® Settings

This section provides information on some desired changes and options available to fine tune your system. Once you are more familiar with the contents of this section, you may find that the 'G3® Quick Guide' at Appendix 1 provides an easier guide for quickly navigating around the system and its various menus.

### Changing the Child Lock FUNCTION

When the Child Lock is enabled, access to the G3®'s functions and menus is restricted, eliminating the possibility of accidental changes being made to your system settings. When your system is "locked" a small picture of a child holding a stop sign will appear in the top right corner of the Current Status screen.

If the Child Lock is on, you will need to **temporarily** unlock the screen, before you can change any settings, including the Child Lock.

To do so press the CHILD LOCK icon (top right hand corner) followed quickly by the bottom left hand corner of the screen, and repeat until the Child Lock icon disappears. If this does not work at first, keep trying but go faster.

With the Child Lock temporarily off, you can turn the Child Lock off permanently if you wish. You do this by pressing the CHILD LOCK button until OFF appears (the CHILD LOCK button "toggles" between on and off.). You reach this button by pressing MENU in the Current Status screen then MORE on the MAIN MENU 1 screen to take you to MAIN MENU 2, then SYSTEM MENU.

When Child Lock is turned OFF, you or anyone else will be able to access all the menus and change any setting by pressing the screen and menu buttons.

NOTE: If you do not turn the Child Lock off permanently, it will automatically be activated when you next return to the Current Status screen after making any changes, or after approximately 60 seconds of inactivity.

To turn the Child Lock ON, go to press MAIN MENU 2, SYSTEM MENU and press the CHILD LOCK button until ON appears.

### Turning your DVS® On and Off

Go to the POWER menu by pressing MENU on the Current Status Screen. This will take you to MAIN MENU 1. Press POWER. This allows you to turn your whole DVS® system ON or OFF via the MODE button, or to operate on pre-set TIMER settings via SET TIMER button.

#### *MODE Selection*

Press MODE to change the POWER setting to either:

- ü ON (RECOMMENDED for normal use) The DVS® system will run continuously, except when it may be automatically turned off according to the Preset settings in use.
- ü OFF (NOT RECOMMENDED for normal use.) The DVS® system will remain turned off until ON or TIMER is selected.
- ü SET TIMER (NOT RECOMMENDED for normal use.) The DVS® system turns on and off according to times set.

**IMPORTANT SAFETY NOTE:** Although the Air Handling Unit and other equipment attached to the DVS® may be switched off via the touch screen control panel or may have turned itself off because of your timer selection, it is still connected to the house power supply. You **MUST** disconnect electrical power to your DVS® by unplugging the Air Handling Unit's 3-pin plug before changing the DVS® air filter or undertaking any other servicing of your DVS® system.

## Increasing Heat Recovery

Although condensation control will normally be the primary purpose of your DVS<sup>®</sup>, there are two functions that enable you to balance the control of condensation with the retention of heat within your home or capture of heat within your roof space.

These functions are Retain Home Heat and Solar Heat Boost.

With Retain Home Heat ON, the flow of air into your home is regulated so that when the roof space temperature is significantly colder than your home, airflow will be reduced.

With Solar Heat Boost ON, the airflow will increase to take advantage of the warmer air in the roof space when it is warmer than the air in your home.

To access these functions, press MORE on MAIN MENU 1 to take you to MAIN MENU 2, which includes a HEAT REC button. Press this and you will have the option to set *Retain Home Heat* and *Solar Heat Boost* ON or OFF.

## Changing Airflow

The AIRFLOW menu enables you to adjust and fine-tune the airflow level higher or lower than the pre-set calibrated level (represented by the '0' setting). The adjusted AIR FLOW will apply to all FAN PROFILE settings.

### *Using the Up and DOWN Fan Controls*

In MAIN MENU 1 press AIRFLOW to open the AIRFLOW MENU. To change airflow, press the UP or DOWN arrows on the right hand side of the screen.

The AIR FLOW setting of '0' is the calibrated and recommended level of airflow to achieve winter-time condensation control for your home.

**NOTE:** Improving Control of Condensation.

If you are not achieving adequate control of condensation at the current AIR FLOW level, experiment by increasing the AIR FLOW by one level at a time to increase the airflow slightly. Try each new AIR FLOW level for 3-4 days to judge the result.

If you wish to reduce the amount of air entering your home during winter, AND your existing AIR FLOW setting is adequately controlling condensation, experiment initially by ensuring that Retain Home Heat is ON. You can also try reducing the AIR FLOW level by one level at a time to slightly reduce the airflow. At some point the AIR FLOW will NOT be sufficient to control condensation. This point will vary depending on the weather, outside temperatures and other factors causing condensation. Try each new AIR FLOW level for 3-4 days to judge the result.

Please do not hesitate to call our service staff on 0800 387 387 if you can not achieve satisfactory results.

### *Using Fan Boost*

FAN BOOST changes the airflow to maximum fan speed for a selected period of time. Once the timer has expired the airflow will revert to the speed determined by the AIRFLOW menu. Pressing FAN BOOST cycles through 1/2HR, 1HR, 1 1/2HR or 2HR and OFF).

This option is useful for clearing the house quickly of extra moisture or smells.

**NOTE:** The fan will be noisier at this speed.

## Changing Seasons

### *Preset Reminder*

The PRESET reminder screen will appear when the preset reminder timer has counted down to 0 months. This is a reminder that it could be time to change your pre-set from SUMMER to WINTER or

WINTER to SUMMER. (Whether or not you make the change will be determined by the actual weather being experienced at the time.)

The screen will alternate between white and black and show a message about changing your preset when the reminder timer has counted down to zero. When you press the screen it will take you to the PRESET MENU and the counter will automatically reset to 6 months - this can be adjusted by pressing the UP/DOWN arrow, to reflect the period you actually want the next reminder to appear. You can also, should you desire, turn the reminder OFF.

### *Changing between Presets*

To change between SUMMER, WINTER and SPR/AUT touch the word "Preset" on the Current Status Screen. This will automatically change between the three Presets. Normally the WINTER and SUMMER options will provide an acceptable level of seasonality.

It is possible for you to change the presets to values different from the ones that DVS<sup>®</sup> has set on installation. This is not necessary, but may be required if your circumstances change such as a significant increase in the number of people living in the house (and creating moisture).

Please do not hesitate to call our service staff on 0800 387 387 if you need help.

### *Creating New Presets*

The PRESET function allows you to save any change that you have made to Air Flow or Heat Recovery settings as new Presets. This enables you to use the settings that you have used this year for the same season next year. For example, you could save the changed settings that you have used this summer as the new presets for use next summer. Normally you will only create and save new presets for the season you are in.

To save the current settings as the new Preset for a particular season, from within the PRESET MENU press SAVE and then either 'Winter', 'Summer' or 'Spr/Aut' to store your current settings. The setting will be saved under the option selected.

Please note that if you have made a change to airflow or heat recovery settings outside of the Preset settings, the word 'Altered' will appear on the Current Status screen below the season it applies to. To see what has changed, go to PRESET and select VIEW. This will show the Preset and Current settings side by side. If you save the changed settings as your Preset, the word 'Altered' will disappear.

In VIEW you will see a setting for Fan Profile, but this is not one that the home owner will change – DVS service staff may use this setting in conjunction with major changes to your configuration if you add new equipment. If you have fitted an air warmer or auto summer vent, settings for these will appear as well. Information about changing these settings will be provided with the equipment.

## **Resetting or Changing the Clock**

As mentioned previously, a power interruption will cause the CLOCK to lose its settings. All other G3<sup>®</sup> settings including any pre-set TIMER settings will be saved during a power interruption. However, any TIMER settings will be inactive until the CLOCK has been reset.

The Clock will also need to be changed at the start and end of daylight savings.

### *Setting the Clock*

It is important to check and set the CLOCK correctly as all TIMER settings rely on the correct day and time being programmed.

Press the day/time figures on the Current Status screen or press the MENU and MORE buttons to bring up the MAIN MENU 2 screen. Select SYSTEM menu and then press SET CLOCK.

Select today's day and time by pressing the DAY, HOUR and MIN buttons (to make them change faster hold the button down). If you go past your desired day and/or time, just keep pressing the DAY, HOUR and MIN buttons until the desired day and/or time re-appears. Press EXIT to finish.

NOTE: This is a 24 hour clock so please ensure that the correct time is set, e.g. 4.30pm should be set as 16:30.
--

## **Changing the Filter Service Reminder**

The FILTER reminder screen will appear when the filter service timer has counted down to 0 months. This is a reminder that your filter should be changed or serviced. We recommend changing your filter approximately every 12 months. The filter reminder timer will have been set by our installer at the time of installation.

NOTE: Once you enter the FILTER menu, it will automatically re-set the due period to 12. Any other time frame can be set by using the UP/DOWN arrows. DVS<sup>®</sup> will either install a replacement filter for you in conjunction with a 10 point service of your DVS<sup>®</sup> system, or deliver a replacement filter for you to fit. We recommend that you order a DVS<sup>®</sup> filter and system service every second or third year in order to correctly maintain your system.

When the filter service reminder screen appears, it is time for a filter service. Please call us on 0800 DVS DVS (387 387) to arrange a filter servicing or to order a filter. "Appendix 2" provides information on how to change your filter.

### Changing Screen Contrast

To Adjust the Screen Contrast for easier viewing if the LCD screen is too dark or light. Use the MENU and MORE buttons to bring up the SYSTEM MENU then access and adjust the Screen Contrast to best suit its position in your home and the surrounding conditions.

### De-activating the Screen for Cleaning

To de-activate the touch screen for 30 seconds to allow the surface to be cleaned (with a soft dry cloth), press and hold down the '387 387' numbers at the bottom of the screen for 5 seconds until the screen goes blank and a message "Touch screen disabled to allow cleaning" appears. After 30 seconds, the screen will return to the Current Status screen. Repeat if more time is needed to complete cleaning. See Section below on Care of Your LCD screen

### Care of Your DVS-G3<sup>®</sup> LCD Touch Screen

The LCD touch screen is a sensitive piece of electronic equipment. To get the best performance and longest life possible from your screen please follow the guidelines below:

- ü The display panel is made of glass. While the G3<sup>®</sup> LCD Screen and Control panel is quite robust, do not subject the screen to a mechanical shock by knocking or hitting the surface, or pressing it with excessive force;
- ü If the display panel is damaged and the liquid crystal substance leaks out, avoid getting any in your mouth. In case of ingestion please contact the National Poison Centre 0800 764 766 (0800 POISON) for advice. If the substance contacts your skin or clothes, wash it off using soap and water;
- ü Do not apply excessive force to the display surface of the LCD module when pressing as it is soft and easily scratched;
- ü Do not scratch the surface with a hard or sharp object;
- ü DO NOT use any solvents to clean the screen as they may damage the polarised surface of the glass. In particular do NOT use water, ketone or aromatic solvents under any circumstances.

To clean the screen surface, first de-activate the touch screen for 30 seconds by pressing on the 387 387 phone number at the bottom of the screen and holding it down for 5 seconds. Alternatively, if the CHILD LOCK is activated this will lock the screen. Then breathe on the face plate and wipe it gently with any lint-free, soft, dry cloth or tissue to remove any dirt or smudges from the screen.

## G3<sup>®</sup> Quick Guide

<b>Turn Your DVS<sup>®</sup> Off</b>	MENU – POWER – MODE: OFF
<b>Turn Your DVS<sup>®</sup> On</b>	MENU – POWER – MODE: ON
<b>Increase Airflow</b>	Touch Fan Icon or MENU – AIR FLOW – UP Arrow or, MENU- AIR FLOW- FAN BOOST-MAX SPEED (select time)
<b>Decrease Airflow</b>	MENU – AIR FLOW – DOWN Arrow
<b>Change Preset Selection</b>	Touch PRESET on CURRENT STATUS screen. Will change from Summer to Winter to Spr/Aut and back or MENU – PRE-SET – SELECT – WINTER/SUMMER/SPR/AUT
<b>View Current Pre-set Settings</b>	MENU – PRESET – VIEW - WINTER/SUMMER/SPR/AUT
<b>Save New Pre-set Settings</b>	MENU – PRESET- SAVE- into WINTER/SUMMER/SPR/AUT
<b>Reminder to Change Pre-set</b>	MENU – PRESET – REMINDER – UP/DOWN for number of months or turn OFF
<b>Change Fan Profile</b>	MENU – MORE- FAN PROFILE – Use UP and DOWN arrows to cycle to desired profile
<b>Heat Recovery</b>	Touch one of the small houses or MENU – MORE- HEAT REC- RETAIN HOME HEAT ON/OFF MENU – MORE- HEAT REC-SOLAR HEAT BOOST ON/OFF
<b>Set Clock</b>	Time Icon – DAY/HOUR/MIN button until current time reached MENU- MORE- SYSTEM MENU- SET CLOCK
<b>Change Screen Contrast</b>	MENU – MORE – SYSTEM MENU – SCREEN CONTRAST - UP/DOWN arrows.
<b>Unlock Child Lock</b>	Touch Top Right - Bottom Left – Top Right – Bottom Left until Icon disappears (DO IT QUICKLY)
<b>Turn Child Lock On/Off</b>	MENU – MORE –SYSTEM MENU - CHILD LOCK ON/OFF
<b>Reset Filter Reminder</b>	MENU – MORE – MORE – FILTER – Press UP or DOWN Arrow until you reach required number of months. Note automatically resets to 12. (We recommend that your filter be changed every 12 months)
<b>Suggested Winter Set Up</b>	POWER: ON, FAN SPEED: 0, FAN PROFILE: Winter 7, (South Island UNIFORM 5) HEAT RECOVERY: SOLAR HEAT BOOST ON, HEAT RETAIN ON
<b>Suggested Summer Set Up</b>	POWER: ON, FAN SPEED: 0, FAN PROFILE: Uniform 6, (South Island UNIFORM 5) HEAT RECOVERY: OFF.

## Filter Replacement Instructions

### For Your Safety

Please take special care when climbing into your roof-space, and while in the roof-space walk only on load-bearing roof beams or trusses. We suggest you ensure another person is in the house or tell a neighbour you are climbing into your roof-space so that you can get assistance quickly if you slip or have an accident.

Switch your DVS® OFF at the control panel - refer to Specific Operating Guidelines for your model of DVS®.

Disconnect the DVS® Air Handling Unit from the house supply by unplugging the 3-pin plug before servicing or changing the air filter. Use only a dry cloth when cleaning the unit. Do NOT remove, open or attempt to service any DVS equipment while it is connected to the house power supply.

Before going into the roof-space to change your DVS® filter:

- ü Ensure that you have 1 filter and 4 plastic ties (3 if a small filter), a clean dry cloth, and a good torch or safety lamp,
- ü Join the ties together to form one long tie, but DON'T connect into a circle yet,
- ü If you have purchased an Activated Charcoal Odour and Smoke Filter (to remove smoke or other smells), please refer to the instructions supplied with that filter.
- ü Switch your DVS® system OFF at the control panel.
- ü Read these instructions and refer to the diagram below.

Carefully enter the roof-space. Take care not to stand on or trip over the DVS® ducting or electrical cables connecting the DVS® Air Handling Unit, other equipment and in-roof control box.

With a pair of strong scissors (recommended) or sharp utility knife, carefully cut the plastic tie holding the used filter to the inlet flange of the DVS Air Handling Unit. Pull away the used filter. If a plastic spacer has been installed in your existing filter, remove and carefully insert into the new filter.

Use the dry cloth to wipe any fine dust from the Air Handling Unit impellor and inside of the inlet flange.

Pull the new filter over the inlet flange, connect and tighten the new long plastic tie around the filter.

Remember to switch your DVS® back on at the control panel in your home.

You may also need to clean any dust from the ceiling outlet(s) and surrounding ceiling in the house with a clean brush or dry cloth. Do NOT use a wet cloth.

Please note that in the vast majority of cases, dust around the ceiling diffuser is the result of dust already inside the home being attracted by tiny electrostatic charges that build up on the surface of the ceiling or diffuser as the incoming air brushes past these surfaces.

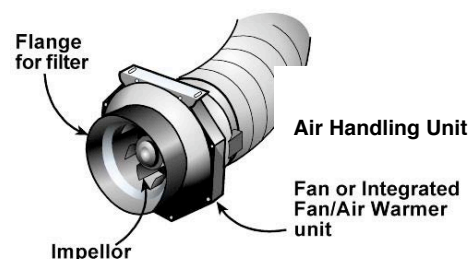
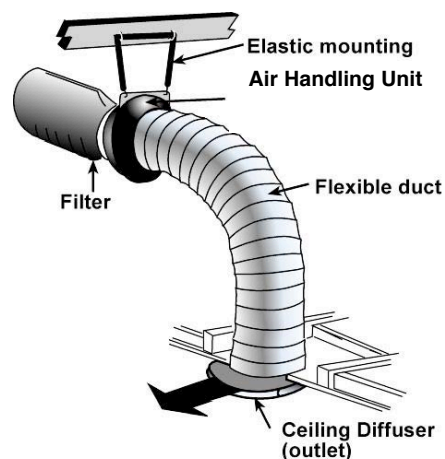

## Answers to Commonly Asked G3® Questions

### ***Why can I hear an occasional 'beep' from the LCD screen?***

The DVS-G3® will beep when touched and if any of its reminder alerts have been activated. There are three reminder alerts programmed into the DVS-G3® - the filter change reminder alert, the power failure alert and the preset reminder alert. If the filter change alert has activated, phone us on 0800 DVS DVS (0800 387 387) to organise a replacement. If the power failure alert has activated, all you need to do is reset the clock. With the preset reminder alert you need to consider if it is time to change from Summer to Winter or vice versa, based on current weather patterns. All other settings will revert to those in use prior to the power failure.

### ***Why does it 'beep' when I press the touch screen, but nothing changes?***

The screen will beep under very light contact but the touch mechanism will only activate under moderate pressure. Try pressing slightly harder and also check that Child Lock is OFF.

### ***When I use my touch screen, it makes a slight buzzing noise. Is this normal?***

All LCD touch screens emit a faint 'buzz' when they are activated. This is normal and will stop when the screen is no longer in use, and returns to Screen Saver mode.

### ***How do I clean the LCD touch screen?***

See 'Care of Your DVS-G3® LCD Touch Screen' on page 7 of this Operating Guide.

*You will find other frequently asked questions about home ventilation in general in our booklet 'General Guidelines and Principles for All DVS® Systems'*

## Menu Settings

This Appendix describes and provides instructions for setting each of the seven touch screen menus.

### MAIN MENU 1

#### POWER MENU

The POWER menu allows you to turn your whole DVS® system ON or OFF via the MODE button, or to operate on pre-set TIMER settings via SET TIMER button.

**NOTE:** While the Air Handling Unit (and other equipment attached to the DVS®) will be switched off when OFF or because of your timer selection, they are still connected to the house power supply. Disconnect the DVS® fan from the house power supply by unplugging the 3-pin plug before changing the DVS® air filter. DO NOT open, remove or service any DVS® equipment while it is connected to the house power supply.

#### MODE Selection

Press MODE to change the POWER setting to either:

- ON      RECOMMENDED. The DVS® system will run continuously, except when it may be automatically turned off according to the FAN PROFILE setting chosen (see Section 4.4 below).
- OFF     NOT RECOMMENDED. The DVS® system will remain turned off until ON or TIMER is selected.
- TIMER   RECOMMENDED for SPECIFIC CIRCUMSTANCES ONLY.



#### AIR FLOW MENU

The AIR FLOW menu enables you to adjust and fine-tune the airflow level higher or lower than the pre-set calibrated level (represented by the '0' setting). The adjusted AIRFLOW will apply to all FAN PROFILE settings.

The AIR FLOW setting of '0' is the calibrated and recommended level of airflow to achieve winter-time condensation control for your home.

Press the UP arrow to increase fan speed and air flow. Press the DOWN arrow to decrease fan speed and air flow.

#### FAN BOOST

Changes the airflow to Maximum for the period selected. Once the timer has expired the air flow will revert to the speed determined by the AIR FLOW menu. This option is useful for clearing the house quickly of extra moisture or smells.

**Note:** The fan will be noisier at this speed.

#### PRESET MENU

The PRESET function allows you to store, view and recall three customised settings for operating your G3® system. Each setting will be unique to your home and lifestyle. The PRE-SET function allows these settings to be saved and re-activated the following year.

Please note that having selected a PRESET and then made a change outside of the PRESET settings the word 'altered' will appear on the Main Menu screen alerting you to this fact. To see what has changed, go to PRESET VIEW and this will show the Preset and Current settings side by side.

#### SAVE

The PRESET SAVE function allows you to save any change that you have made to Air Flow or Heat Recovery settings as new Presets. This enables you to return to those settings for the same season the following year. Normally you will only create and save new presets for the season you are in.

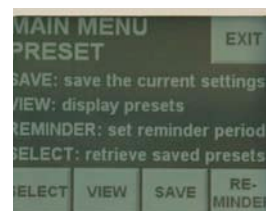
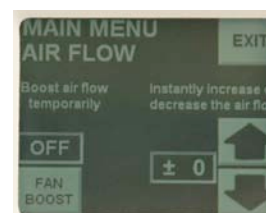

Press SAVE and then either 'Winter', 'Summer' or 'Spr/Aur' to store your current settings into that particular season. The setting will then be saved under the option selected.

**SELECT**

Press SELECT and then 'Winter', 'Summer' or 'Spr/Aur' to recall a previously saved setting. The 'DVS' button will return your DVS® to the recommended general settings for your home.

**VIEW**

Press VIEW to display Presets and to compare your Current settings to those saved when the word "altered" appears on the Current Status screen.

**REMINDER**

Press REMINDER to re-set or change the time period for next pre-set change reminder or to turn reminder OFF.

Note: After you have saved or selected your settings you will be returned to Main Menu 1 screen.

**MAIN MENU 2**

**FAN PROFILE**

The FAN PROFILE menu enables you to select one of 30 pre-set programmes which control the way the DVS® Air Handling Unit responds to changes in roof-space temperature. However, depending on whether you have an Air-Warmer or Auto Summer Ventilation unit installed, you will normally only use two profiles during the course of a year, i.e. Winter and Summer.

The profiles are grouped in 4 types, in the following order

Winter	5 profiles
Summer	5 profiles
Uniform	5 profiles
Auto Summer Vent	4 profiles

To change and select a FAN PROFILE, simply press the UP or DOWN arrow and scroll through the profiles until you reach the setting you require.

If you are unsure which profile is the most appropriate for your circumstances and for the season, or if you would like any other advice, please phone us on 0800 DVS DVS (387 387).

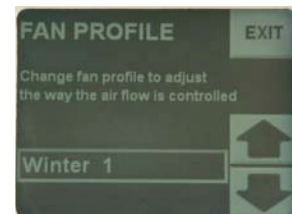

**HEAT REC (Heat Recovery)**

The HEAT REC (Heat Recovery) function allows your DVS G3® to further regulate and fine-tune the airflow into your home to give you the best combination of condensation control and heat recovery/retention. This is done via the Retain Home Heat and Solar Heat Boost functions which can independently be turned ON or OFF.

The Retain Home Heat function measures the difference in temperature between your home and the roof-space and, when selected, it will automatically reduce the airflow if the roof-space is colder than inside your home.

The Solar Heat Boost will increase the airflow if the roof-space is warmer than the home.

**NOTE:** High-end and low-end temperature cut-outs for all Fan Profiles still apply if the Heat Recovery function is ON.



**SYSTEM MENU**

The SYSTEM menu allows you to set your CLOCK, adjust the Screen CONTRAST and activate or de-activate the CHILD LOCK.

**SET CLOCK**

Press the Day/Time on the Current Status screen or press the MENU and MORE buttons to bring up the Main Menu 2 screen. Select SYSTEM menu and then press SET CLOCK.

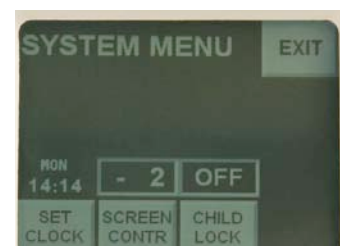

Select today's day and time by pressing the DAY, HOUR and MIN buttons (to make them change faster hold the button down). If you go past your desired day and/or time, just keep pressing the DAY, HOUR and MIN buttons until the desired day and/or time re-appears.

**Note:** this is a 24 hour clock so please ensure that the correct time is set, e.g. 4.30pm should be set as 16:30.

### SCREEN CONTRAST

Press MENU and MORE to access the SYSTEM menu on Main Menu 2. Select SCREEN CONTR.

Adjusting the screen CONTRAST changes the lighting of the DVS-G3<sup>®</sup> touch screen to best suit its position in your home and surrounding lighting conditions. Press the UP or DOWN arrows to increase or decrease the contrast for maximum screen clarity.

### CHILD LOCK

Press MENU and MORE to access the SYSTEM menu on Main Menu 2. Press CHILD LOCK ON to activate a screen 'lock' each time you return to the Current Status screen. When the CHILD LOCK function is activated, a small picture of a child holding a stop sign will appear in the top right corner of the Current Status screen.

To temporarily unlock the screen, and enable you to change any settings, press the CHILD LOCK icon (top right hand corner) followed by the bottom left hand corner of the screen, and quickly repeat until the Child Lock Icon disappears. The CHILD LOCK will automatically be activated when you next return to the Current Status screen after making any changes, or after approximately 60 seconds of inactivity.

To turn the CHILD LOCK function OFF, select OFF in the CHILD LOCK menu. When turned OFF, you or anyone else will be able to access all the menus and change any setting by pressing the screen and menu buttons.

### MAIN MENU 3

#### FILTER REMINDER

The FILTER reminder screen will appear when the filter timer has counted down to 0 months remaining until the filter is due to be changed or serviced. We recommend changing your filter approximately every 12 months.

NOTE: once you enter the FILTER menu, it will automatically re-set the due period to 12. Any other time frame can be set by using the UP/DOWN arrows. DVS<sup>®</sup> will either install a replacement filter for you in conjunction with a 10 point service of your DVS<sup>®</sup> system, or deliver a replacement filter for you. See "Appendix 2" on how to change your filter.

